

# Guidelines for Using a Pulsar™ DC Pulsing Accessory with an SCR-Fired DC Power Supply

*Recommended equipment and setup for optimum process performance*

*When upgrading older SCR-fired DC power supply equipment proves too costly in your PVD sputtering processes, use the Advanced Energy® Pulsar™ DC pulsing accessory to achieve improved film quality and higher throughput. This application note describes how to effectively install a Pulsar accessory with an SCR-type power supply for optimum process performance, including recommended equipment, guidelines for circuit construction, and other installation precautions.*

## Products

Pulsar™ DC pulsing accessory

## Applications

PVD sputtering processes equipped with SCR power supplies

## Who Benefits

OEM and end-user process engineers

## Cost-Benefit: When to Use a Pulsar™ DC Pulsing Accessory

Large power-delivery systems (>60 kW) for PVD sputtering processes vary from modern switching supplies with excellent arc handling to older SCR-type power supplies (thyristors) with slow arc detection and high arc energy. As thin films become more sophisticated, the requirement for better arc handling and longer processing times between cleaning cycles increases almost exponentially. However, upgrading from an SCR power supply to a switching supply, or even migrating to an AC delivery system, can prove costly.

Placing an Advanced Energy® Pulsar™ DC pulsing accessory between a DC power supply and the cathode can enhance the quality of film produced with newer supplies and markedly improve the performance of older SCR power supplies. In addition, a Pulsar accessory installed in this type of delivery system extends processing

times between cleaning cycles at higher power, which equates to increased throughput. With the Pulsar accessory, the cost per SCR delivery system tends to be quite low compared to the alternatives.

## Pulsar™ Accessory Requirements and Setup

Adding the Pulsar accessory to a modern switching DC delivery system is straightforward and requires only small modifications to the arc-handling menus. Refer to the Pulsar user manual for normal operation.

Placing a Pulsar accessory between the cathode and an older SCR power supply, however, is a little more complicated. Effective installation and application requires the following recommended equipment and circuit construction:

- Pulsar 80 kW unit with 20% reverse voltage
- Triaxial output cables of equal length that connect the Pulsar accessory and the cathode

- *Arc-inhibit circuit that connects the Pulsar ArcSynch™ signal to the SCR power supply's arc-trigger circuit*
- *Optional bypass circuit on the input and the output of the Pulsar accessory to enable a more efficient cleaning cycle*

### Pulsar 80 kW Unit with 20% Reverse Voltage

Advanced Energy offers two Pulsar options—a 40 kW option and an 80 kW option. The 40 kW option is designed for low-power switching supplies that have fair to good arc handling. The 80 kW option was designed to accommodate SCR power supplies with large cathodes. The reverse pulse is 20% of the working voltage, and the front end of the 80 kW option can withstand the high currents associated with the slow arc handling of SCR power supplies. This option can handle up to 200 A and 80 kW and can easily be stacked to reach 400 A and 160 kW.

### Triaxial Output Cables

Advanced Energy has performed strenuous testing and found that a 4 AWG triaxial cable, available from Industrial Electric Wire & Cable (Appendix A), has the best properties for running up to 100' (30.48 m) between the Pulsar accessory and the cathode. This cable can handle up to 100 A maximum pulsed DC current, so two cables of equal length are required for each Pulsar 80 kW output. For a 160 kW stack, four equal-length cables are required.

### Arc-Inhibit Circuit

SCR power supplies traditionally have very slow arc-response times. There is, at least in the SP120 line of supplies, an external arc-trigger input that you can use effectively with the Pulsar accessory. You may experience *banding* on the substrate during the time that the SCR power supply performs its arc-handling routine. Sometimes the Pulsar accessory releases the crowbar while the SCR power supply is still trying to get through its arc routine, and the end result is an arc count of two or three on the Pulsar accessory for each arc event. This keeps the power to the cathode off for too long. If you experience these types of occurrences, you can construct a circuit (Figure 1) to link the Pulsar ArcSynch signal to the SCR power supply's external arc trigger.

The Pulsar accessory has its own arc-response settings to handle all of the arcs in the plasma. If the arcs become too frequent and/or too strong, the Pulsar accessory will enable a crowbar on the input line, signaling the power supply to go into its own arc-handling routine. When the Pulsar accessory enables its crowbar, the ArcSynch signal prompts the SCR power supply's external arc trigger to initiate its arc-handling routine. The SCR power supply will start its arc-response routine much faster when using this circuit. Note that some older SCR power supplies do not have this option, so this circuit is not used.

### Bypass Relays

If a cleaning cycle is required during the course of operation with the Pulsar/SCR power supply stack, then you can employ the circuit shown in Figure 2 to achieve high-quality target cleaning. Advanced Energy has found that the Pulsar accessory handles *all* arcs effectively. During the cleaning cycle, it is imperative that the oxide layer that is built up on the target surface gets blown off by excessively large arcs in this high-powered, high-voltage, argon-rich atmosphere. The Pulsar accessory is not well equipped to be a source of large arc events. In fact, it is designed to limit the arc energy delivered to the cathode as much as possible. Therefore, a bypass circuit is necessary.

During the cleaning cycle, the circuit enables the common arc-handling capacitor installed in the cathode lid that almost all SCR power supplies and some European switching supplies use. The Pulsar accessory will switch out of the power-delivery circuit during the cleaning cycle. Relays that are used as the main contactor in the SP120 supplies are a good source and can easily handle up to 200 A in pulsing mode.

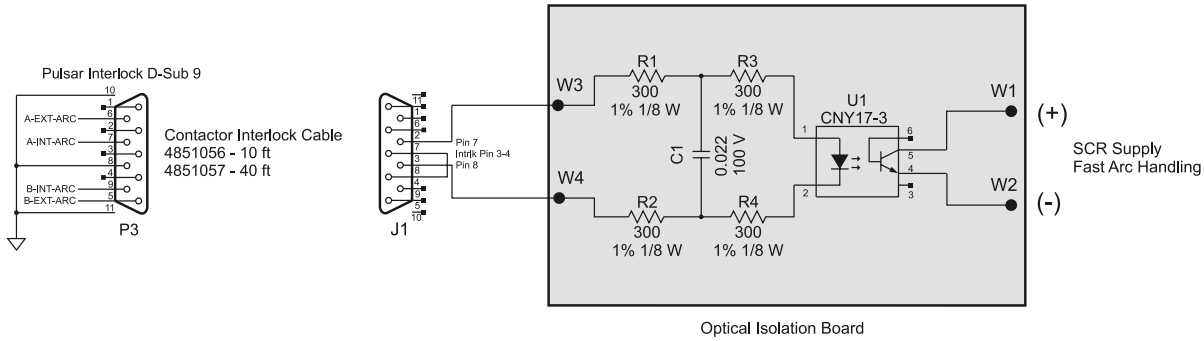

Figure 1. You can assemble an arc-inhibit circuit to connect the Pulsar™ ArcSynch™ signal to the SCR power supply's arc-trigger circuit for faster arc response times.



Figure 2. A bypass relay circuit can switch the Pulsar™ accessory out of the circuit during cleaning cycles.

## Installation Precautions

### Insert Digital Output in DC Power Supply Interlock String

Never enable the DC power supply output unless the Pulsar accessory is powered on and ready for operation. There is an output on the rear of the Pulsar accessory that is *Unit OK*. Insert this digital output in the DC power supply interlock string so that the DC output will not energize unless the Pulsar input power (110 VAC or 220 VAC) is on. Refer to this in the Pulsar manual under the heading *Communication Interfaces*.

### When Using Arc-Inhibit Circuit, Remove Components Between the Pulsar™ Accessory and the Cathode

At no time can there be anything other than a cathode generating plasma on the load of the Pulsar accessory. Older SCR power supplies (and some newer European switching supplies) sometimes have a capacitor installed at the cathode to aid in arc handling. This capacitor is crude but mostly effective for supplies that cannot

react efficiently to arcs. There may also be an arc diverter at the cathode. This, too, is for supplies that cannot react fast enough to the tug of arcing. Traditionally, arc diverters are not very robust and tend to break on a regular basis. Any capacitors, arc diverters, or other components of this nature between the Pulsar accessory and the cathode *must* be removed for optimum Pulsar operation.

### Adjust SCR Settings if You Do Not Use Arc-Inhibit Circuit

If you use the older SCR power supply with the arc-inhibit circuit described above, you do not need to adjust the power supply's *Arc Level*, *Pre-Inhibit Delay*, or *Post-Inhibit Delay* settings. However, if you do not use the arc-inhibit circuit with the SCR power supply, you need to adjust (in most cases, lower) these values for stable operation.

## Appendix A: Triaxial Output Cables

Cable USA manufactures 4 AWG triaxial output cables with the following properties.

These cables are available for purchase from:

Industrial Electric Wire & Cable®

800.989.9502

<http://www.iewc.com>

### Scope

This specification details a special-purpose 4 AWG flexible cable. It is rated for 125°C (257°F) and 2,000 V<sub>RMS</sub> maximum continuous use.

Item	Description	Diameter
<b>Center Conductor</b>		
Material	Tin Plated Copper	0.260" Nom.
Size	4 AWG, 133 x 25	
<b>Inner Dielectric</b>		
Material	Extruded FEP	0.324" Nom.
Wall Thickness	0.030" Nom.	
Color	Natural	
<b>Conducting Shield</b>		
Material	Four Layers Tin Plated Copper Braid	0.430" Nom.
Size	34 AWG (9 ends per carrier x 24 carriers x 4 layers = 864 ends total)	
<b>Outer Dielectric</b>		
Material	Extruded FR TPR	0.526" Nom.
Wall Thickness	0.048" Nom.	
<b>Ground</b>		
Material	Three Layers Tin Plated Copper Braid	0.606" Nom.
Size	34 AWG (12 ends per carrier x 24 carriers x 3 layers = 864 ends total)	
<b>Jacket</b>		
Material	Extruded FR TPR	0.700" Nom.
Wall Thickness	0.048" Nom.	
Color	Black	
<b>Specifications</b>		
Voltage Rating	2,000 V <sub>RMS</sub>	
Temperature Rating	125°C (257°F) Maximum Continuous, (200°C (392°F) Inner Dielectric)	
Weight	513 Lbs/1,000' Nom.	



2584 Horseshoe Drive S

Naples, FL 34109

239.643.6400

[www.cableusa.cc](http://www.cableusa.cc)

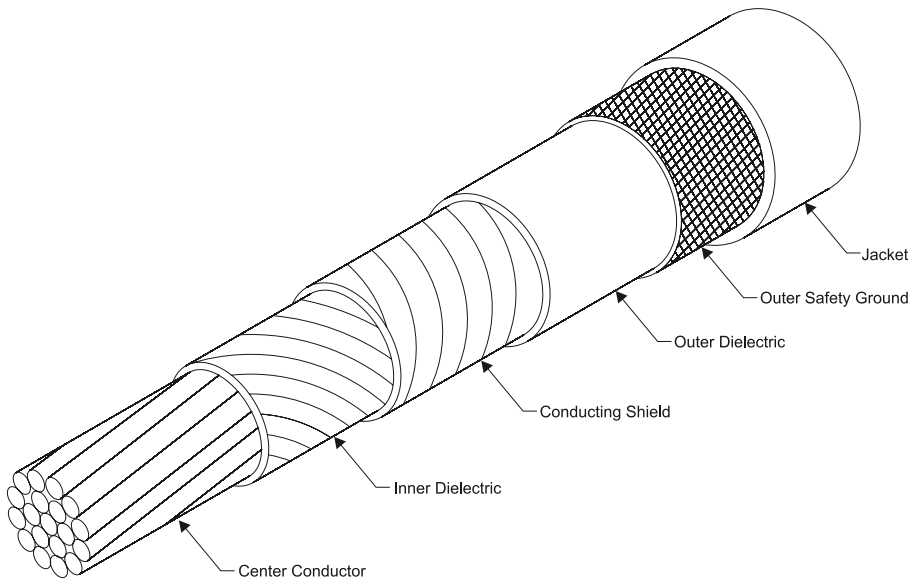

Specifications are subject to change without notice.



Advanced Energy Industries, Inc. • 1625 Sharp Point Drive • Fort Collins, Colorado 80525 U.S.A.  
T: 800.446.9167 or 970.221.4670 • F: 970.221.5583 • [support@aei.com](mailto:support@aei.com) • [www.advanced-energy.com](http://www.advanced-energy.com)  
Please see [www.advanced-energy.com](http://www.advanced-energy.com) for worldwide contact information.

© Advanced Energy Industries, Inc. 2007  
All rights reserved. Printed in U.S.A.  
ENG-Pulsar4CSR-260-02 0M 4/07